

Power Redistributor Applied to Distribution Transformers

Aniel Silva de Moraes

Federal University of Santa Catarina - UFSC
Power Electronics Institute - INEP
Caixa Postal: 5119 | Cep: 88040-970
Florianópolis, Brazil
aniel@inep.ufsc.br

Ivo Barbi

Federal University of Santa Catarina - UFSC
Power Electronics Institute - INEP
Caixa Postal: 5119 | Cep: 88040-970
Florianópolis, Brazil
ivobarbi@inep.ufsc.br

Abstract – This paper presents a three-phase four-wire active filter applied as a power redistributor to compensate power unbalance among the phases of the distribution transformer. It provides the compensation of the fundamental negative sequence component, harmonic and neutral currents, implying the improvement of power quality indexes and reliability of the distribution power system.

I. INTRODUCTION

Nowadays the major challenge of electric power distribution sector is to maintain the quality of service according to the standards proposed by international committees [1]. However the cost factor is supposed to be analyzed in detail.

Great part of the total cost involved in the electric system is related to distribution, due to the expansion of the consuming market, replacement of equipment, maintenance and losses. Therefore the improvement of efficiency in distribution has a considerable economic impact in the planning of power systems [1, 2].

The distribution system is inherently dynamic, since the load demand is not constant in time and the loading of the phases is asymmetrical. Planning the expansion of systems is then essential to assure that the continuous changes of demand and utilization factor of equipments are satisfied for the additional or modified systems, which obey clearly defined quality goals.

The application of static compensators to the electric power system is a practice that has been intensified with the development of the three-phase active filters. The basic concept was proposed in the 1960's [3], but it became popular in during the 1980's with the work proposed by Akagi and Nabae [4]. In distribution systems, one can mention the application of the DSTATCOM's (Distribution Static Synchronous Compensators), DVR's (Dynamic Voltage Restorer) and UPQC's (Unified Power Quality Conditioner) [5, 6].

This work proposes an equipment that is not supposed to compensate the reactive power, since the necessary power would be considerably high. The term "redistributor" will be used in this work, since the main goal of the converter is to redistribute and to balance the complex power flow supplied by the system to the distribution transformer.

The following advantages can be addressed to the proposal [1]:

- The use of the converter allows to postpone investments in the distribution system;
- Losses are supposed to be reduced due to elimination of neutral currents in transformers;

- Equilibrium among the voltage drops across the secondary windings of the transformer is obtained;
- Increase of the service capacity to the consumer due to the improvement of the utilization factor of equipments;
- Increase of reliability and quality of services, due to the aforementioned advantages.

This work also intends to foment the discussion on the application of power electronics as a viable solution to problems regarding the distribution system, and also on the choice of hybrid actions involving conventional and electronic equipment.

II. THE POWER REDISTRIBUTION CONCEPT

This work aims to present an equipment able to provide power redistribution in a three-phase system in a dynamic way [7]. Therefore it is necessary to explain some relevant concepts regarding the proposal. Fig. 1 presents an example to illustrate the basic idea. The system supplies unbalanced loads, emphasizing the power redistribution among the phases due to the transfer of complex power.

The values of load impedances are arbitrarily chosen. The filter impedances (Z) are designed to compensate the unbalances of the load. Capacitors and inductors compensate the reactive power, and the resistances compensate the active power.

One can see in Fig. 1 that in the third branch of the filter (Z) resistance $RA3$ is positive and, therefore, it dissipates energy of the system. However, resistances $RA1$ and $RA2$ are negative, behaving as voltage sources controlled by current. Considering a fictitious "coupling" among the resistances, which makes possible the energy transfer among them, the total active energy in the filter is null. This assumption has didactic nature so that the concept of power redistribution can be explained better.

An interesting analogy can be obtained between the performance of an active filter processing active power among the phases and the resistive "coupling". When the active filter compensates unbalanced loads, it should balance the system transferring energy from a phase to the other. During this process, the energy is stored in the output capacitor through one of the input branches, and then drained from the capacitor to another branch.

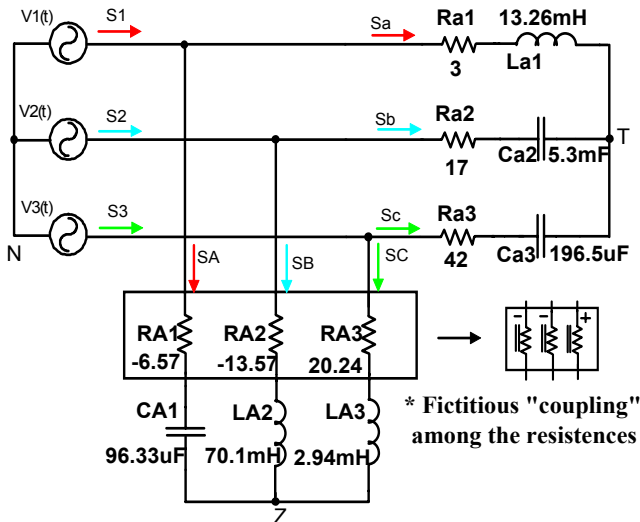

Fig. 1 – Unbalanced loads emphasizing the power redistribution among the phases due to the active power transfer.

Fig. 2 presents the waveforms obtained with the example in Fig. 1, for three-phase currents considering balanced voltages, the power balance is obtained indirectly through the currents.

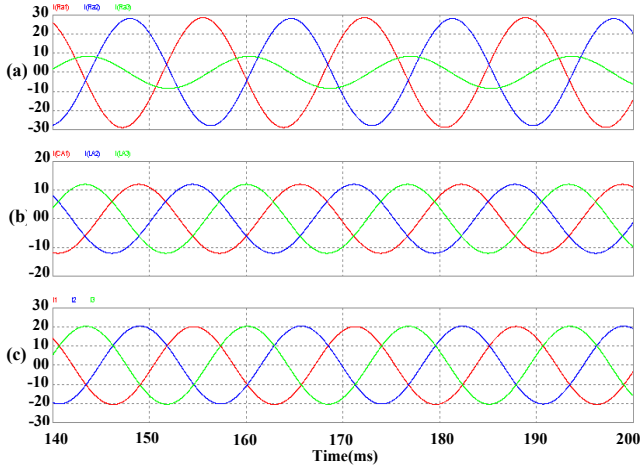

Fig. 2 – Three-phase current waveforms for: (a) Load, (b) Passive Filter and (c) Input.

The three-phase instantaneous power is shown in Fig. 3. Fig. 3 (a) corresponds to the load powers, as the unbalance provides the appearance of negative sequence components in the three-phase instantaneous active power and in the imaginary power. In order for the filter to balance the system, the oscillatory part of both powers must be compensated, as seen in Fig. 3 (b). In Fig. 3 (c), the input instantaneous powers are constant as desired.

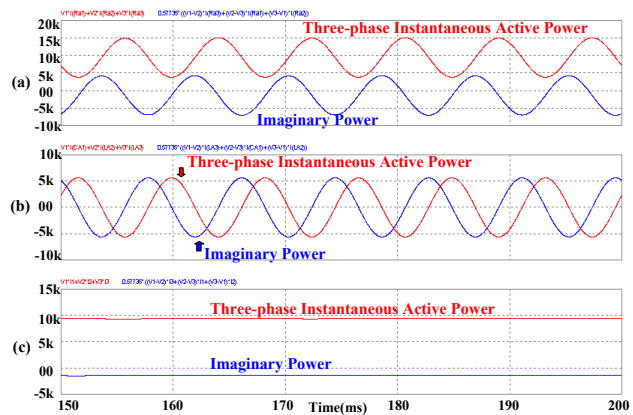

Fig. 3 – Instantaneous three-phase power (a) Load, (b) Filter and (c) Input.

III. UNBALANCE POWER INDEX

The balance of the total complex power is based on the balance of the complex power in each phase of the three-phase distribution transformer. According to [2], the unbalance of complex powers is given by expressions (1) to (3).

$$\Delta_S = \sqrt{\frac{1}{3} \sum_{p=1}^3 (S_p - S_0)^2} \quad (1)$$

$$S_0 = \frac{S_a + S_b + S_c}{3} \quad (2)$$

$$\Delta_S (\%) = \frac{\Delta_S}{S_0} \cdot 100\% \quad (3)$$

where S_0 and S_p represent the average loading and the loading in phase p of the transformer, respectively, as parameter p is a, b or c . If $\Delta_S = 0$, the transformer is perfectly balanced.

IV. CONVERTER POWER

Analyzing the unbalance index Δ_S , which is an inherent characteristic of radial systems, one can design the converter to be applied as a redistributor of complex power. The design of this converter is function of Δ_S , since it is supposed to compensate the unbalance.

Analyzing (1), significant information can be obtained. The difference among the complex powers of phases a, b , and c and the average value is given by (4). Substituting (4) in (1), expression (5) results.

$$\begin{cases} \Delta_{SA} = |S_0 - S_a| \\ \Delta_{SB} = |S_0 - S_b| \\ \Delta_{SC} = |S_0 - S_c| \end{cases} \quad (4)$$

$$\Delta_S = \sqrt{\frac{1}{3} \cdot (\Delta_{SA}^2 + \Delta_{SB}^2 + \Delta_{SC}^2)} \quad (5)$$

Considering that phase a is the most unbalanced one, there are two possible extreme cases:

- Larger dispersion: when one of the phases assumes the average value, as expression (6) is obtained.

$$\Delta_{SA} = \sqrt{3/2} \cdot \Delta_S \cong 1.225 \cdot \Delta_S \quad (6)$$

- Smaller dispersion: two phases have the same values, as expression (7) is obtained.

$$\Delta_{SA} = \sqrt{2} \cdot \Delta_S \cong 1,414 \cdot \Delta_S \quad (7)$$

From the previous results, one can establish that, if the unbalance index of a given system is known, one can determine an operation band for the phase with largest loading, included in the interval determined by (8).

$$\sqrt{3/2} \leq \frac{\Delta_{SA}}{\Delta_S} \leq \sqrt{2} \quad (8)$$

This simple analysis allows to estimate the required power and design the converter to be used as power redistributor. For the worst case, $\Delta_{SA} = \sqrt{2} \cdot \Delta_S$ is adopted as a situation of extreme operation, and expression (9) results.

$$S_{Redist.} = 3 \cdot \Delta_{SA} = 3 \cdot \sqrt{2} \cdot \Delta_S \cong 4,24 \cdot \Delta_S \quad (9)$$

The maximum power processed by the converter is equal to two thirds of the power estimated in the design. It can be explained since one of the phases processes the maximum capacity, and the remaining ones should process the same amount of power. Expression (10) presents the calculation of the complex power processed by the converter as a function of Δ_S .

$$\begin{cases} S_p = \Delta_{SA} + \Delta_{SB} + \Delta_{SC} \\ \Delta_{SA} = \Delta_{SB} + \Delta_{SC} = \sqrt{2} \cdot \Delta_S \\ S_{Proc} = 2 \cdot \sqrt{2} \cdot \Delta_S \cong 2,828 \cdot \Delta_S \end{cases} \quad (10)$$

V. THREE-PHASE FOUR-WIRE PWM CONVERTER WITH SPLIT-CAPACITOR AND CONTROL STRUCTURE

A. Three-Phase Four-Wire PWM Converter with Split-Capacitor

In order to obtain simulation results and illustrate the subsequent statements, the converter presented in Fig. 4 was designed using the dq0 transformation. The transfer functions of the converter were obtained, between the input current and the duty cycle (11), and between the output voltage and the input current with the dq0 transformation (12), [8].

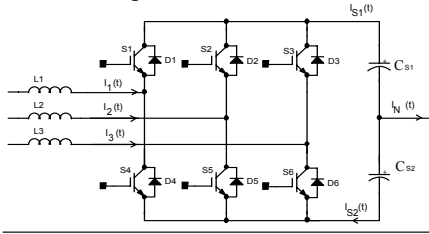

Fig. 4 – Three-phase four-wire PWM converter with split-capacitor.

$$\begin{cases} \frac{i_0(s)}{\tilde{d}_0'(s)} = -\frac{V_S}{L \cdot s + R_S} \\ \frac{i_d(s)}{\tilde{d}_d'(s)} = -\frac{V_S}{L \cdot s + R_S} \\ \frac{i_q(s)}{\tilde{d}_q'(s)} = -\frac{V_S}{L \cdot s + R_S} \end{cases} \quad (11)$$

$$\begin{cases} \frac{V_S(s)}{i_d(s)} = \frac{\sqrt{6} \cdot V_{pk}}{s \cdot V_S \cdot C_S} \cdot \left[1 - \left[\frac{2 \cdot S_p \cdot (1-\eta) \cdot (2 \cdot R_S + s \cdot L)}{3 \cdot V_{pk}^2} \right] \right] \\ \frac{V_S(s)}{i_q(s)} = -2 \cdot \sqrt{\frac{2}{3}} \cdot \frac{S_p}{V_{pk} \cdot V_S} \cdot \left[\frac{L \cdot s + 2 \cdot R_S}{s \cdot C_S} \right] \\ \frac{V_S(s)}{i_0(s)} = \frac{\sqrt{3}}{s \cdot C_S} \end{cases} \quad (12)$$

where V_S is the output voltage, R_S is the series equivalent resistance for each one of the three branches, L is the boost inductance, V_{pk} is the peak input voltage, C_S is the output capacitance, η is the converter efficiency, and S_p is the complex power processed by the converter.

B. Control Structure

Fig. 5 shows the main block diagram, where the converter is placed in the secondary side of a distribution transformer, in parallel with a four-wire unbalanced load. The converter is supposed to compensate the unbalance as well as the harmonic components of the load current, [9, 10].

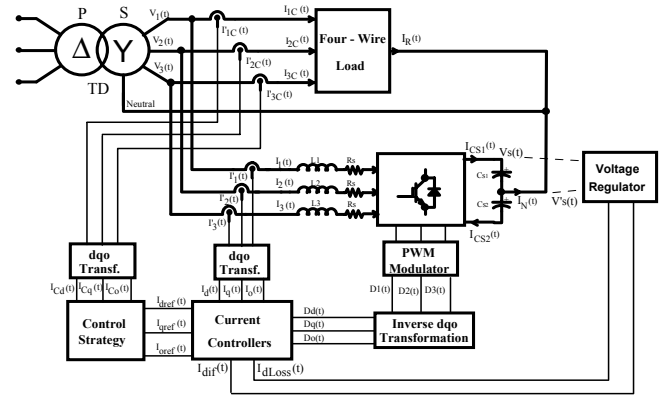

Fig. 5 – Main block diagram.

The control strategy presented in this work consists in the compensation of instantaneous currents. If the voltages are unbalanced with positive, negative and zero sequence components, the currents will be balanced.

According to Fig. 6 (a), the control system is based on the dq0 transformation applied to the converter currents, which are taken to the compensators in Fig. 6 (b).

The total output voltage and the voltage across capacitor C_{S2} are measured and applied to the voltage regulator block, composed by two distinct controllers. The first one controls the total output voltage, compensating the converter losses, represented by current $I_{dLoss}(t)$. The second one corrects the voltage across the output capacitors, as the output signal is called difference current $I_{Dif}(t)$.

Both currents are applied to the current controllers, since $I_{dLoss}(t)$ and $I_{Dif}(t)$ are added to $I_{dref}(t)$ and $I_0(t)$, respectively. The voltage regulator is shown in Fig. 7 (a), where gains and low-pass filters are used to eliminate the alternate components of the voltages.

The output signals of the current controllers are the duty

cycles in dq0 coordinates. The inverse dq0 transformation is used in Fig. 7 (b), as duty cycles $d_1(t)$, $d_2(t)$ and $d_3(t)$ are applied to the modulator block.

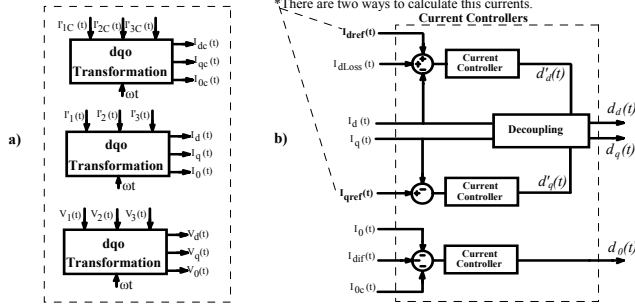

Fig. 6 – (a) Dq0 transformation of load currents, converter currents and input voltages; (b) Current controllers.

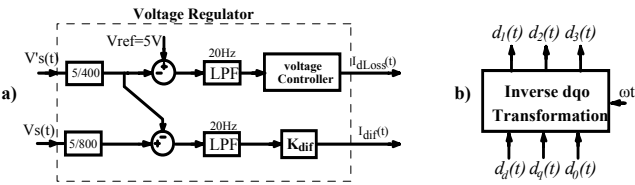

Fig. 7 – (a) Voltage regulator; (b) Inverse dq0 transformation.

The adopted control strategy defines the reference currents. Firstly, the load currents must be measured and converted to the dq0 system. Fig. 8 (a) shows the reference currents calculated from the load currents. Currents $\tilde{I}_{dc}(t)$ and $\tilde{I}_{qc}(t)$ are alternate parts of sequence components d and q , respectively.

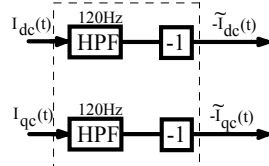

Fig. 8 – Control strategy considering the currents as reference

VI. SIMULATION RESULTS

In order to compare the aforementioned theories and to validate the theoretical assumptions about the instantaneous current control, simulation results are presented. The parameters set used in the design are shown in TABLE I.

TABLE I
DESIGN PARAMETERS

Rms line voltage (V_{ac})	220Vrms
Line frequency (f_L)	60 Hz
Output voltage (V_S)	800Vcc
Switching frequency (f_S)	20kHz
Boost inductor (L)	700μH
Output capacitor (C_S)	14.1mF

The unbalanced voltages given by (13) are used in the converter simulation.

$$\begin{cases} v_1(t) = 310 \cdot \sin(\omega t + 8^\circ) \\ v_2(t) = 325 \cdot \sin(\omega t - 117^\circ) \\ v_3(t) = 300 \cdot \sin(\omega t + 123^\circ) \end{cases} \quad (13)$$

Fig. 9 presents the input voltages, input currents, load currents and converter currents.

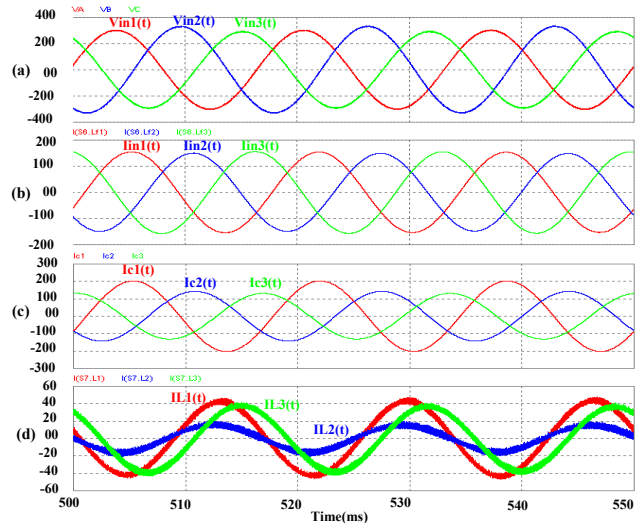

Fig. 9 – (a) Input voltages; (b) Input currents; (c) Load currents and (d) Converter currents.

In Fig. 10 one can see the currents in dq0 system for input, load and converter. Components d and q of the input current are practically constant, and the zero sequence current is almost null. The converter processes the alternate part of the load current with the same amplitude.

TABLE II shows the total harmonic distortion of the input current.

TABLE II
TOTAL HARMONIC DISTORTION OF THE INPUT CURRENT

	i_{in1}	i_{in2}	i_{in3}
THD(%)	0.377	0.382	0.441

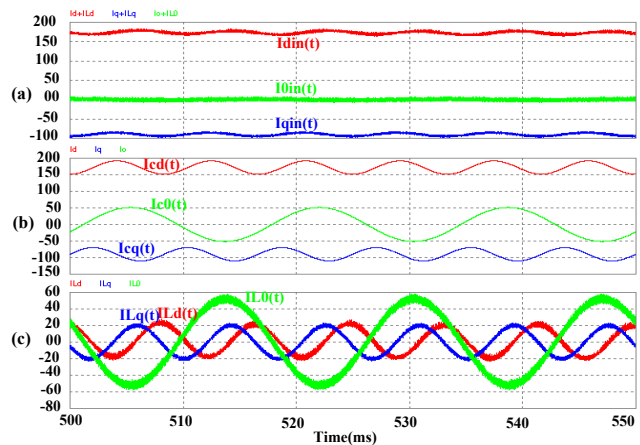

Fig. 10 – Currents in dq0 system: (a) Input current; (b) Load current and (c) Converter current.

Fig. 11 presents the instantaneous active and reactive

three-phase powers for the input, load, and converter. The converter is not able to compensate the alternate components in the three-phase instantaneous powers satisfactorily.

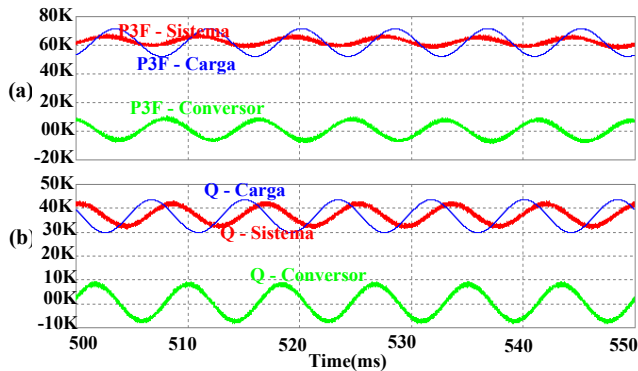

Fig. 11 – Three-phase instantaneous powers: (a) Active power; (b) Reactive power.

Fig. 12 presents simulation results when the converter is used in the compensation of nonlinear loads.

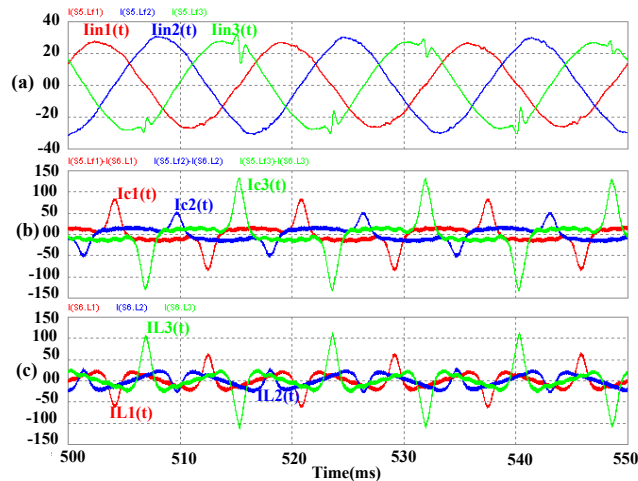

Fig. 12 – Nonlinear loads: (a) Input current; (b) Load current and (c) Converter current.

It can be seen that this technique allows the separation of the currents according to the components that will be compensated e.g. reactive components, harmonics, negative or zero sequence components.

VII. CONCLUSION

This paper has presented a converter applied as power redistributor. For a three-phase balanced system, the neutral conductor can be ignored and capacitor banks can be used for the correction of the displacement power factor. Three-phase hybrid converters are also a viable alternative, as great part of the power is processed by passive elements, while the converter is supposed to compensate the dynamic part. Some harmonic components can be compensated using dedicated hybrid filters.

VIII. ACKNOWLEDGMENT

The authors gratefully acknowledge the financial support provided by CNPQ, UFSC and INEP.

IX. REFERENCES

- [1] A.B. Knolseisen, “Planejamento de Sistemas de Distribuição com Enfoque na Qualidade dos Serviços e no Desbalanceamento das redes”. Dissertação de Mestrado em Engenharia Elétrica, Universidade Federal de Santa Catarina, Florianópolis, Brasil.
- [2] T.H. Chen, J.T. Cherg, “Optimal Phase Arrangement of Distribution Transformers Connected to A Primary Feeder for System Unbalanced Improvement and Loss Reduction Using A Genetic Algorithm”, *IEEE Transactions on Power Systems*, [S. 1], pp. 994-1000, Aug. 2000.
- [2] M. Depenbrock “The FBD-method, a generally applicable tool for analyzing power relations”, *IEEE Transactions on Power Systems*, vol 8, pp. 381-386, May. 1993.
- [4] H. Akagi, Y. Kanazawa, A. Nabae, “Instantaneous Reactive Power Compensators Comprising Switching Devices without Energy Storage Components”, *IEEE Transactions on Industry Application*, vol. IA-20, pp. 625-630, 1984.
- [5] A. Ghosh, A. Joshi, “The Concept and Operating Principles of A Mini Custom Power Park”, *IEEE Transactions on Power Delivery*, vol. 19, n.º 4, October 2004.
- [6] A. Ghosh, G. Ledwich, “Load Compensating DSTATICOM in weak AC Systems”, *IEEE Transactions on Power Delivery*, vol. 18, Nº 4, October 2003.
- [7] Z. Chen, “Three-Phase Four-Wire System Power Redistribution Using A Power Electronic Converter”, *IEEE Power Engineering Review*, October 2000.
- [8] D. Borgonovo, I. Barbi, Y.R. Novaes. “A Three-Phase Three-Switch Two-Level PWM Rectifier”, *Record of the 34th IEEE Power Electronics Specialists Conference*, vol. 3, June 2003, pp. 1075-1079.
- [9] M. Aredes, “Active Power Line Conditioners”, Dr.-Ing. Thesis, Technischen Universität Berlin, Berlin, Germany, March 1996.
- [10] P. Verdelho, G. Marques, “An active power filter and unbalanced current compensator”, *IEEE Trans. Ind. Electron.* Vol. 44, p. 321-328, June 1997.