

A 12 kW Three-Phase Low THD Rectifier With High-Frequency Isolation and Regulated DC Output

Falcondes José Mendes de Seixas and Ivo Barbi

Abstract—A robust 12 kW rectifier with low THD in the line currents, based on an 18-pulse transformer arrangement with reduced kVA capacities followed by a high-frequency isolation stage is presented in this work. Three full-bridge (buck-based) converters are used to allow galvanic isolation and to balance the dc-link currents, without current sensing or current controller. The topology provides a regulated dc output with a very simple and well-known control strategy and natural three-phase power factor correction. The phase-shift PWM technique, with zero-voltage switching is used for the high-frequency dc–dc stage. Analytical results from Fourier analysis of winding currents and the vector diagram of winding voltages are presented. Experimental results from a 12 kW prototype are shown in the paper to verify the efficiency, robustness and simplicity of the command circuitry to the proposed concept.

Index Terms—AC–DC converter, autotransformer, 18-pulse, harmonics, high-frequency conversion, power factor correction.

I. INTRODUCTION

RECENT ac–dc converters used to supply telecommunication equipment are expected to draw a sine-wave current from the utility, with a power factor very closed to unity and galvanic isolation of the regulated output voltage.

Single-phase rectifiers meeting this requirement are well known and widely used. The standard solution uses a PWM boost dc–dc converter (PFC) following the front-end full-wave diode rectifier. However, in medium power applications (6 kW or higher), the single-phase solution is not convenient and three-phase ac–dc topologies are required.

In the same way that a large number of works have been developed for power factor correction in single-phase systems, the same has happened for the technique applied to three-phase systems [1]. This growth also applies to converters with one or more associated switches, or by using specially connected transformers or even for mixed systems with transformers and static converters.

The simplest solution uses a three-phase diode rectifier, associated to passive filters to minimize the harmonic currents in the mains. Isolation can be obtained by using conventional low frequency Δ/Y transformer, resulting in a robust but, bulky, heavy and expensive equipment. At the opposite extreme, classical three-phase PWM, which requires a circuitry with complex control, modulation and soft-commutation techniques has been

used. The PWM solution at one stage is divided in both isolated and nonisolated converters [2]–[4].

Since isolation and regulated output voltage are not required, polyphase transformer arrangements [5]–[10] and line inter-phase transformers (LIT) [11], [12] are very useful to improve the quality of the utility line currents. These transformers present a reduced kVA capacity. The 18-pulse converter, using an Y or Δ -connected differential autotransformer, is very interesting because it allows natural power factor correction (the two lowest orders of the line current harmonics are the seventeenth and the nineteenth). The autotransformer is designed to feed three six-pulse bridge rectifiers displaced by 20° and rated about 20% of the output kVA. Usually, to provide parallel connection of the rectified output voltages, two Interphase Transformers (IPT) with three windings each one, connected in the dc sides of the three bridge rectifiers, are required to absorb the instantaneous voltage differences between the bridges.

Whenever galvanic isolation and regulated dc output are required, such as in telecommunication systems and others, the challenge is to find a simple, high efficient, high power density, low cost and robust three-phase converter.

This work proposes an 18-pulse isolated rectifier with regulated dc output of 60 V/200 A [13], [14]. This technique uses the same concept of the polyphase autotransformers in order to obtain a “natural” power factor correction, i.e., an ac–dc converter of which the input currents at low THD are in phase with the input voltage, as a resistor emulator, without any active switches. In addition, to include the high-frequency isolation stage and to allow adjustable output voltage at low-level, the current control loop is not necessary and the ZVS-PWM technique for active switches is applied to this topology. The proposed connection for the high-frequency transformers eliminates the interphase transformers and the needs of the current sensing. Therefore, the overall size of the converter and the difficulties of the command circuitry are reduced.

II. CIRCUIT TOPOLOGY

The fundamental concept of the natural power-factor correction through nonisolated polyphase transformer is ensured by the 18-pulse Y-connected autotransformer, followed by three six-pulse diode rectifiers.

The proposed topology is shown in Fig. 1. This solution uses three Full-Bridge converters connected in the dc sides of each three-phase diode rectifier. A small-size high-frequency filter (L_f , C_f) is placed on each dc-link (between the full-bridge converters and the six-pulse diode rectifiers).

Besides the high-frequency transformers allowing isolation between primary and secondary sides, the secondary windings

Manuscript received April 10, 2002; revised September 12, 2003. Recommended by Associate Editor P. K. Jain.

F. J. M. de Seixas is with the São Paulo State University, Ilha Solteira 15385-000, Brazil (e-mail: falcon@dee.feis.unesp.br).

I. Barbi is with the Federal University of Santa Catarina, Florianópolis 88040-970, Brazil (e-mail: inep@inep.ufsc.br).

Digital Object Identifier 10.1109/TPEL.2003.823201

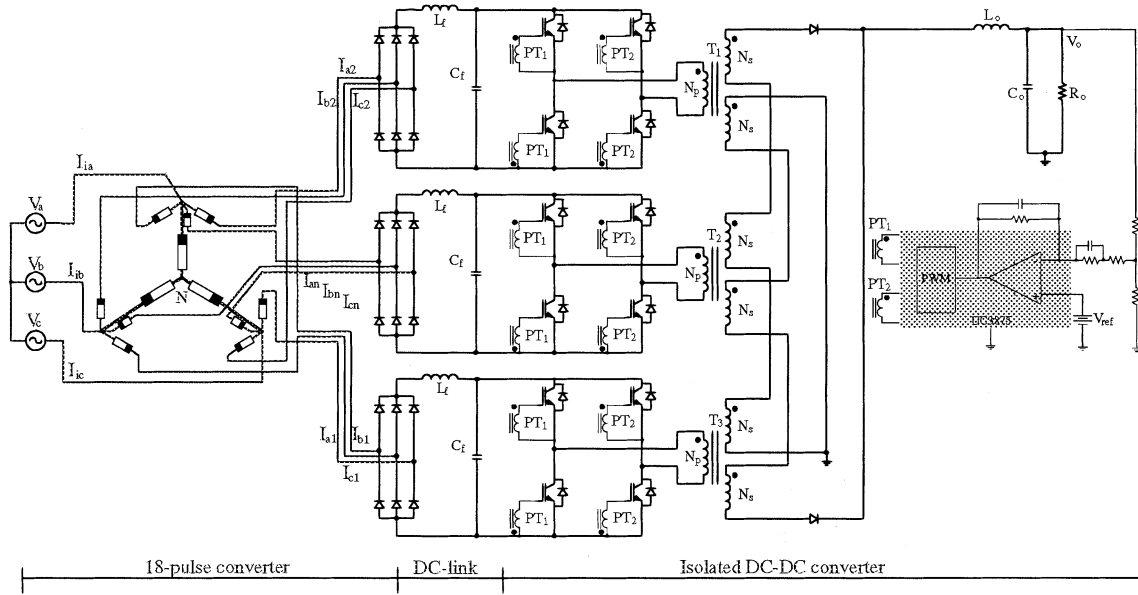

Fig. 1. Proposed low THD ac-dc converter with high-frequency isolation.

are series connected to balance the dc-link currents. This simple and robust strategy eliminates all current sensing and current controllers, usually necessary to balance these currents. However, the full-bridge converters have to be synchronized. To reduce the commutation losses without auxiliary switches, the phase-shifted pulse-width modulation (PS-PWM) technique is applied. The conventional resonant components and snubber circuits are not shown in Fig. 1.

The regulated output voltage is easily obtained through conventional voltage controller. Only one integrated circuit (PS-PWM) [15], associated to some passive components and two pulse-transformers (PT₁ and PT₂), are used for regulation and driving all of the switches. Using the pulse transformers, with two secondary windings, the necessary synchronization among the full-bridge converters is made easily.

A. Analysis of the Autotransformer

The primary windings of the autotransformer are formed of N_a , N_b and N_c , which are Y-connected and linked to the input voltages V_a , V_b and V_c . In this connection, a virtual neutral point N is generated.

The secondary windings are designed, in such a way that, the turns-ratio and the connection between them and the primary winding generate three different three-phase systems with a 20° phase-shift from each other. These voltages feed the rectifiers.

All the windings of N_a , N_{a1} , N_{a2} and N_{an} are coupled together at the same limb core, the resulting voltages V_a , V_{a1} , V_{a2} and V_{an} , are in phase. The same applies to phases “b” and “c.”

A schematic representation of the primary and secondary windings, the electrical connections and the three-phase core used are shown in Fig. 2.

1) *Winding Voltages:* The autotransformer is supplied by a three-phase balanced voltage system. Three diode rectifiers

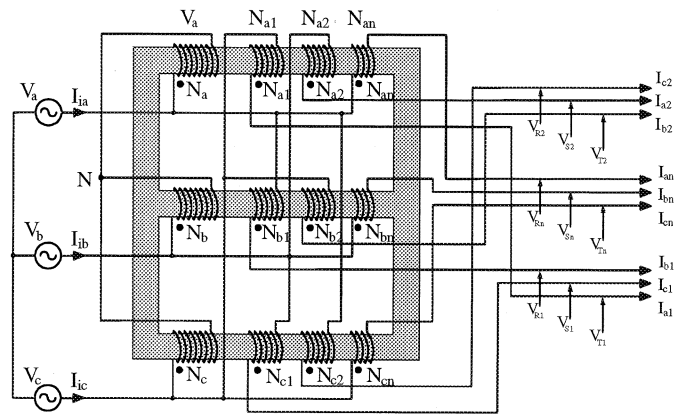

Fig. 2. Scheme of the autotransformer windings.

follow the secondary voltages, composed of three three-phase voltage systems, also balanced. One of these systems is placed in the same phase as the supply voltage and the others are placed at +20° and -20°, with regard to the supply system. The vector diagram and the auxiliary triangle, used to obtain the three voltage systems, are shown in Fig. 3.

The magnitude of the voltages across the secondary windings V_{a1} , V_{a2} , V_{b1} , V_{b2} , V_{c1} , and V_{c2} are obtained by

$$V_{b1} = V_a \cdot \frac{\sin(20^\circ)}{\sin(100^\circ)} = 0.35 \cdot V_a. \quad (1)$$

The winding turns-ratio (K_1) that ensures a phase displacement of 20° is given by

$$K_1 = \frac{V_a}{V_{b1}} = 2.88. \quad (2)$$

This result shows that these secondary turns are 2.88 times lower than the primary turns.

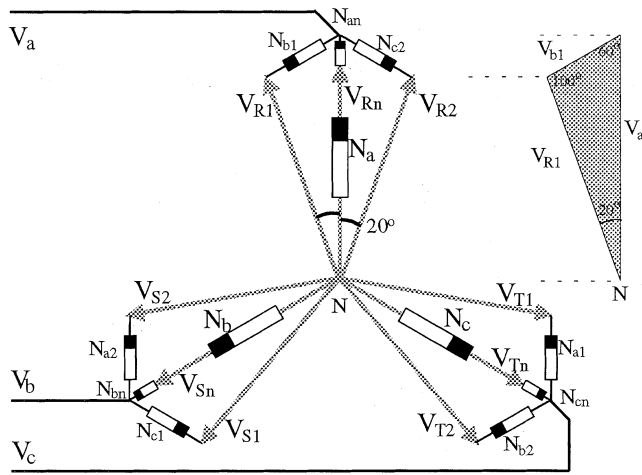

Fig. 3. Vector diagram and auxiliary triangle.

The magnitude voltages between each pair of secondary terminals, (V_{R1} , V_{S1} , V_{T1}) and (V_{R2} , V_{S2} , V_{T2}), with respect to the virtual neutral point, are obtained in

$$V_{R1} = V_a \cdot \frac{\sin(60^\circ)}{\sin(100^\circ)} = 0.88 \cdot V_a. \quad (3)$$

The third secondary three-phase voltage system (V_{Rn} , V_{Sn} , V_{Tn}) is in phase with the primary one. Its voltages however, must have the same magnitude as other secondary voltages. So, (4) must be fulfilled

$$V_{Rn} = V_a - 0.88 \cdot V_a = 0.12 \cdot V_a. \quad (4)$$

The winding turns-ratio that ensures 88% of the primary voltage (K_2), without phase displacement, is given by

$$K_2 = \frac{V_a}{V_{Rn}} = 8.29. \quad (5)$$

This result shows that these secondary turns are 8.29 times lower than the primary turns.

It can observe that the voltage magnitudes of each three-phase system are about 88% reduced in comparison with the input phase voltages.

2) *Winding Currents:* The technique to eliminate harmonic currents in multiple pulse converters requires current-mode operation to the load. The 18-pulse converter is obtained when each output voltage system is connected to a six-pulse diode rectifier. It looks like three identical loads ($I/3$), with current source characteristics, are used.

The current waveform, through one secondary winding (N_{an}), in phase to the input voltage V_a , is shown in Fig. 4. This waveform is adopted as an angular reference to represent the other winding currents.

The waveform of I_{an} can be decomposed in a *Fourier series* by conventional means. By the way, when a discontinuous function is considered, the series terms can be obtained by inspection. It can observe that this waveform presents alternate symmetry, the negative half cycle is an inverted reproduction of the positive half cycle. Thus, the even harmonics are zero and there are no cosine terms. The average value is also zero.

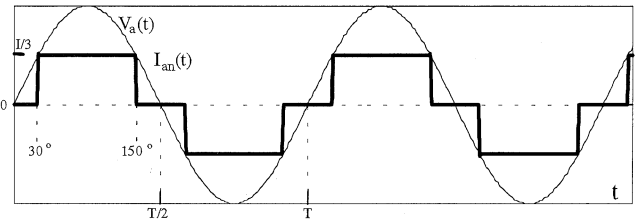

Fig. 4. Primary voltage and secondary current to phase "a."

Note that winding N_{an} conducts current $I/3$ during 120° ($2\pi/3$), starting from 30° ($\pi/6$). Thus, the current expression results in

$$I_{an}(t) = \frac{4}{\pi} \cdot \frac{I}{3} \cdot \sum_k \frac{1}{k} \cdot \cos\left(k \cdot \frac{1}{6}\right) \cdot \sin(k \cdot \omega t). \quad (6)$$

Where, $k = 1, 3, 5, \dots$

The current waveforms through the other secondary windings of this three-phase system (I_{bn} and I_{cn}) are represented by the same equation for I_{an} . Therefore, the phases are displaced in -120° and $+120^\circ$.

In the other secondary three-phase system (displaced by $+20^\circ$), current I_{b1} is expressed in

$$I_{b1}(t) = \frac{4}{\pi} \cdot \frac{I}{3} \cdot \sum_k \frac{1}{k} \cdot \cos\left(k \cdot \frac{1}{6}\right) \cdot \sin[k \cdot (\omega t + 20^\circ)]. \quad (7)$$

The other currents of this three-phase system (I_{a1} and I_{c1}) are represented by the same equation for I_{b1} , but displaced by -120° and $+120^\circ$.

For the last voltage system (displaced by -20°), current I_{c2} is expressed in

$$I_{c2}(t) = \frac{4}{\pi} \cdot \frac{I}{3} \cdot \sum_k \frac{1}{k} \cdot \cos\left(k \cdot \frac{1}{6}\right) \cdot \sin[k \cdot (\omega t - 20^\circ)]. \quad (8)$$

The other currents of this three-phase system (I_{a2} and I_{b2}) are represented by the same equation as for I_{c2} , but displaced by -120° and $+120^\circ$.

The primary winding currents (I_a , I_b and I_c) can be obtained in (9), considering the currents of the three secondary windings coupled at the same limb core and the turns-ratio (K_1 and K_2). As mentioned below, windings with the same index (a, b, or c) are coupled at the same limb. Fig. 5 shows the primary current (I_a)

$$I_a(t) = \left(\frac{I_{a1}(t) + I_{a2}(t)}{K_1} - \frac{I_{an}(t)}{K_2} \right). \quad (9)$$

3) *Line Currents:* Line currents I_{ia} , I_{ib} and I_{ic} are obtained by adding all currents through windings at same node. Therefore, equation for I_{ia} can be represented in

$$I_{ia}(t) = I_a(t) + I_{an}(t) + I_{b1}(t) + I_{c2}(t). \quad (10)$$

Fig. 6 shows the line currents (I_{ia} , I_{ib} and I_{ic}) and Fig. 7 shows the harmonics of current I_{ia} as a % of the fundamental magnitude. It can observe that the 18-pulse converter present only harmonic orders $k \cdot 18 \pm 1$, for $k = 1, 2, 3, \dots$ and the magnitudes are lower than 6% of the fundamental component (I_{ia}).

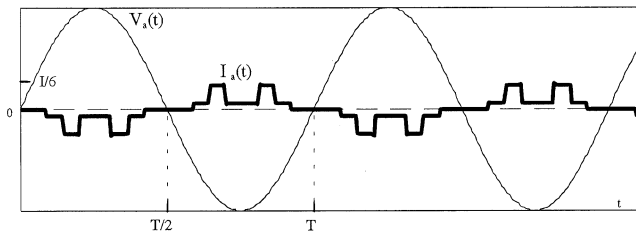

Fig. 5. Primary current to phase "a."

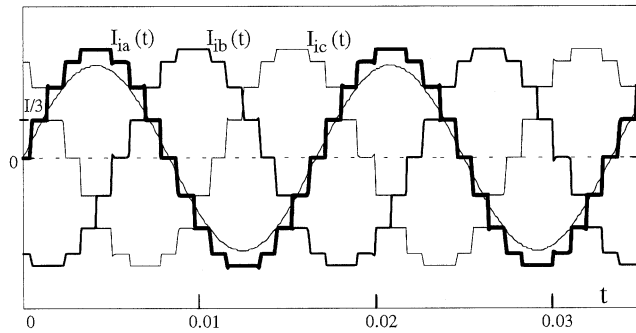
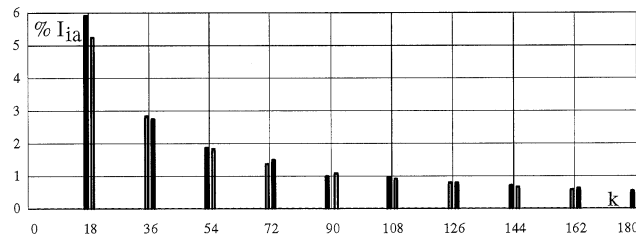

Fig. 6. Three-phase line currents and voltage of phase "a."

Fig. 7. Harmonics of line current I_{ia} .

B. Isolated DC-DC Converter

The isolated converter topology to be chosen, should be a current-fed converter with an almost constant current at the output of each rectifier; in other words, the three dc-dc converters must absorb the balanced currents with low magnitude ripples. Thus, the class of isolated current-fed converters (boost) such as the push-pull and the full-bridge converters are the most attractive.

Balancing the currents can be achieved through current-mode control, monitoring the currents in the dc-link through current sensors. Besides, a voltage regulator that generates only one current reference for the three current regulators can control the output voltage [7].

In this work, the strategy to balance all dc-link currents does not consider any current sensor or current controller. The topology itself balances the currents by means of its power circuit, described as follows.

1) *The Converter Topology:* The topology chosen for the isolated stage was the full-bridge voltage-fed converter with a LC filter at the input. This voltage-fed topology allows employing the soft switching technique through phase-shifted pulse-width modulation (PS-PWM). Therefore, there is no voltage stress across the switches and zero-voltage switching (ZVS) is guaranteed for a wide operation range [15]. The LC resonant components use the output capacitance of the switches and the leakage inductance of the primary windings.

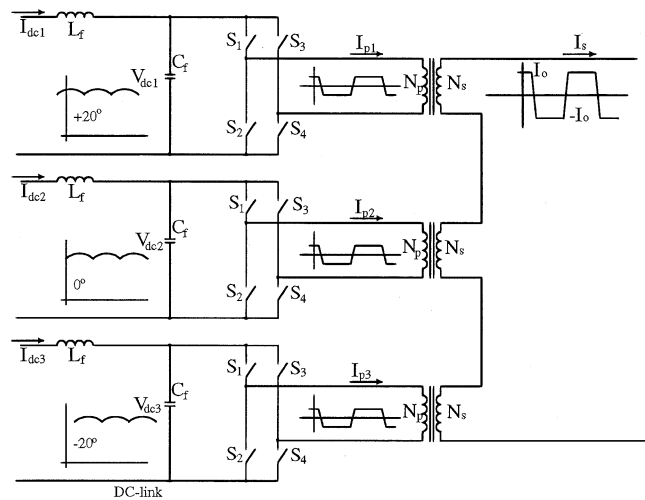

Fig. 8. Circuit to achieve balanced dc-link currents.

The small volume LC filter, installed at the input of the dc-dc converter, is used to filter the current's high frequency components (two times the switching frequency).

2) *Current Balancing:* The three dc-dc converters present the following characteristics.

- They process the same power (1/3 of the total power).
- The rectified voltage systems (six pulses) have the same magnitude, although displaced 20° from each other.
- The average currents through the dc-link are the same.

Current balancing can be reached through a series connection of the secondary windings of the three high frequency transformers and by synchronizing the command of the converters. Thus, the current waveforms of the secondary windings are equal and, due to the transformer turns-ratio, all of the currents through the primary windings are identical ($I_{p1} = I_{p2} = I_{p3}$), as shown in Fig. 8.

Consequently, the instantaneous currents through the three converters are equal. Due to the instantaneous differences between the rectified voltages, the power processed by the dc-dc converters during a switching period is also different. Thus, the frequency ripples of the currents in the DC-links are three times the frequency ripples of the rectified voltages. This effect is a result of the composition of the three rectified voltages (six pulses) with a displacement of 20° . Fig. 8 shows the strategy used to reach balanced currents through the dc-links.

3) *Output Rectifier:* To reduce diode conduction losses, the center-tapped connection is chosen for the output rectifier. Thus, each transformer has two secondary windings, which are connected as shown in Fig. 1. The voltage to be rectified is composed of the sum of the secondary voltages.

Each secondary voltage, whose phase corresponds to its respective dc-link voltage, presents a six-pulse ripple. Then, the output voltage presents an 18-pulse ripple, composed of the three secondary voltages.

4) *Command Strategy:* Fig. 1 shows the command circuit used to reach regulated dc output and synchronization of the three full-bridge converters. Only one well-known integrated circuit can be used to achieve voltage regulation and drive.

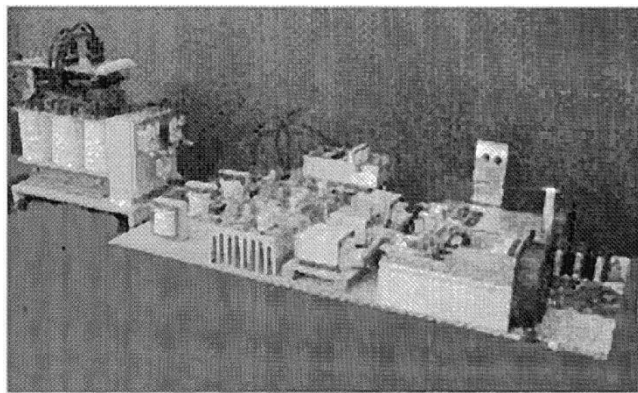

Fig. 9. Prototype of the proposed 12 kW ac-dc converter.

III. EXPERIMENTATION

A. Specifications and the Most Relevant Components

Fig. 9 shows a picture of the complete prototype of the experimented three-phase ac-dc converter.

- Three-phase input voltages: 220/380 V.
- DC Output: 60 V/200 A.
- Switching frequency: $f_s = 30$ kHz.
- $N_a, N_b, N_c = 330$ turns with a 20 AWG wire.
- $N_{an}, N_{bn}, N_{cn} = 40$ turns with a 15 AWG wire.
- $N_{a1}, N_{b1}, N_{c1} = 114$ turns with a 15 AWG wire.
- $N_{a2}, N_{b2}, N_{c2} = 114$ turns with a 15 AWG wire.
- Autotransformer – area of the EI core = 27 cm².
- Three-phase bridges = SKD 30/08 A1 (Semikron).
- $L_f, C_f = 4$ mH, 1.3 μ F.
- IGBT modules = SK 25 GH 063 (Semikron).
- Rectifier diodes = HFA50PA60C (IR).
- $N_p = 13$ turns with a 16 \times 23 AWG wire.
- $N_s = 1$ turn with a 150 \times 23 AWG wire.
- High frequency transformer—EE-65/65 on ferrite core.
- PS-PWM = UC3875 (Texas Instruments).
- $L_o = 2 \times 7.5 \mu$ H—two inductors with EE-65/39 on ferrite core—four turns with a 100 \times 20 AWG wire.
- $C_o = 6 \times 680 \mu$ F/100 V—Electrolytic capacitors.

B. Experimental Results

Fig. 10 shows the waveforms of the dc-link voltage and current with low load for operation **without** connecting the secondary windings in series. It can be observed the high magnitude of the six-pulse ripple of the current. In this operation mode it is not possible to reduce the low harmonics in the line.

The three balanced dc-link currents are shown in Fig. 11. In this case, the low-frequency ripples are minimized and the average currents of the dc-link are the same.

The voltage waveforms of the input of all diode rectifiers and the line voltage, for one phase, are shown in Fig. 12 and the waveforms of the rectified voltages, that feed the full-bridge converters, are shown in Fig. 13. In both it can be observed a displacement of 20° and the balanced magnitude among them.

Fig. 14 shows the waveforms for input current and input voltage in the same phase and Fig. 15 shows all of the line currents (I_{ia} , I_{ib} and I_{ic}). It can observe the shape of input current between experimental result (Fig. 15) and mathematical results

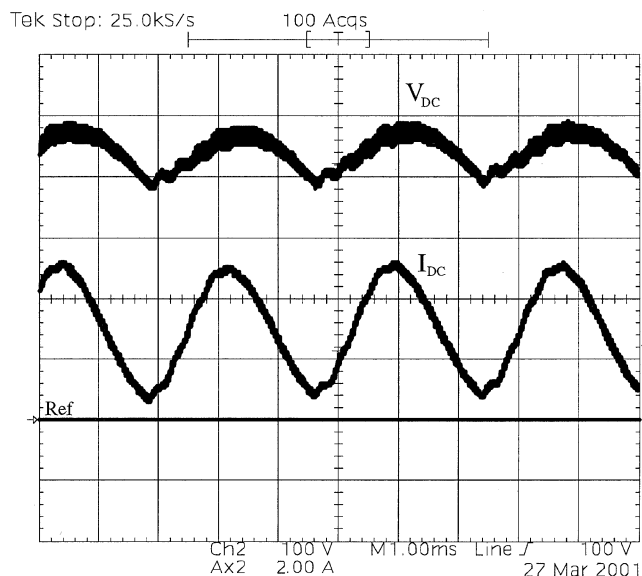

Fig. 10. DC-link voltage and current without series connection of the secondary windings. Scales: 1 ms/div, 100 V/div, 2 A/div.

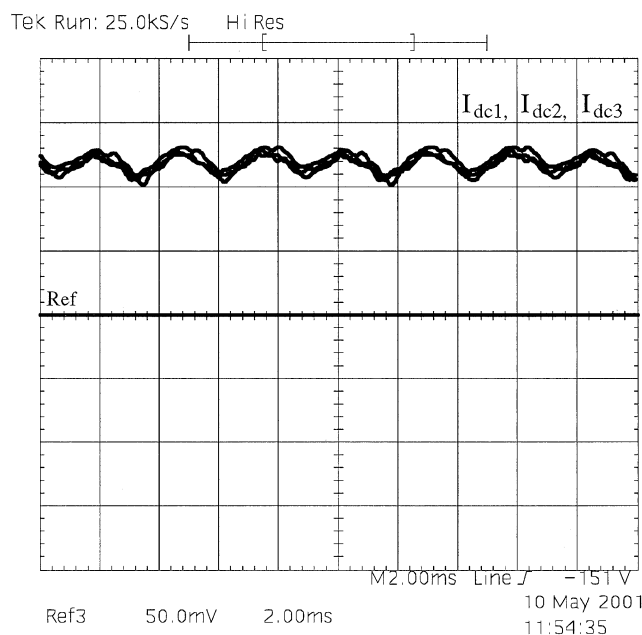

Fig. 11. Balanced dc-link currents. Scales: 2 ms/div, 5 A/div.

(Fig. 6) are the same. The measured input PF and the THD of the input current are equal to 0.99 and 8.6%, respectively.

Fig. 16 shows the efficiency for operation since low load to full load. It can observe the efficiency is higher than 90% for high load.

IV. CONCLUSION

In this work, a robust, isolated ac-dc converter with low THD is presented. The 18-pulse converter is based on an Y-connected autotransformer and followed by three phase-shifted ZVS-PWM full-bridge converters. The secondary windings of the high-frequency transformers are series connected and all of the full-bridge converters are synchronized to achieve balanced dc-link currents. The balance and the low magnitude ripple of

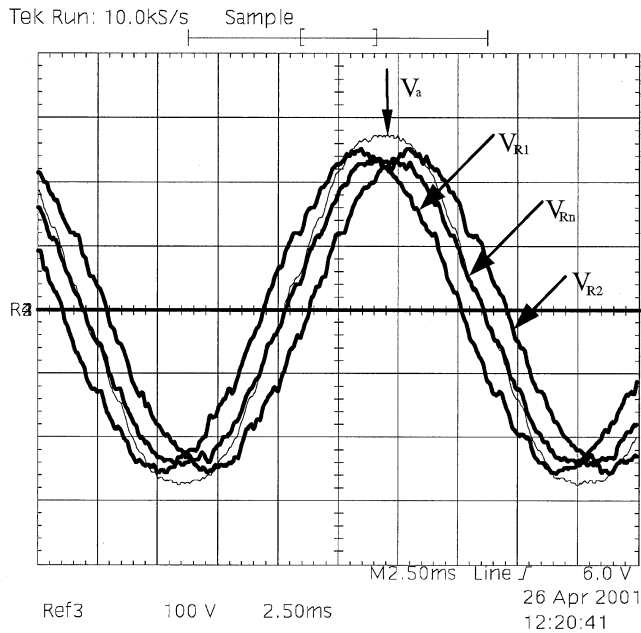

Fig. 12. Line voltage and input voltages of the diode rectifiers. Scales: 2.5 ms/div, 100 V/div.

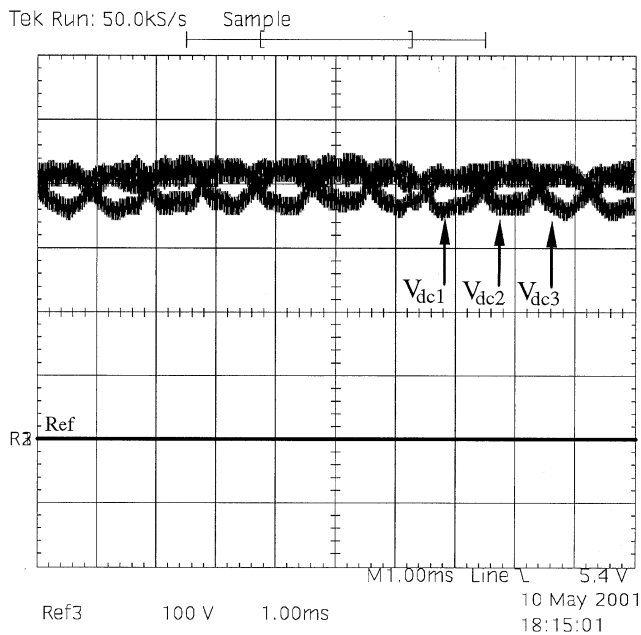

Fig. 13. Rectified voltages through dc-links. Scales: 1 ms/div, 100 V/div.

the dc-link currents are the fundamental requirement to provide reduced harmonic current in the mains. A 12 kW laboratory prototype was implemented and the complete experimental results are presented. The simplicity, robustness and high power density suggest the proposed converter as a strong candidate for modern solutions to three-phase supply systems used in telecommunication, motor drive, UPS and others. Thus, the positive and negative viewpoints of the proposed technique, to help comparing this approach with other topologies, are summarized as follows.

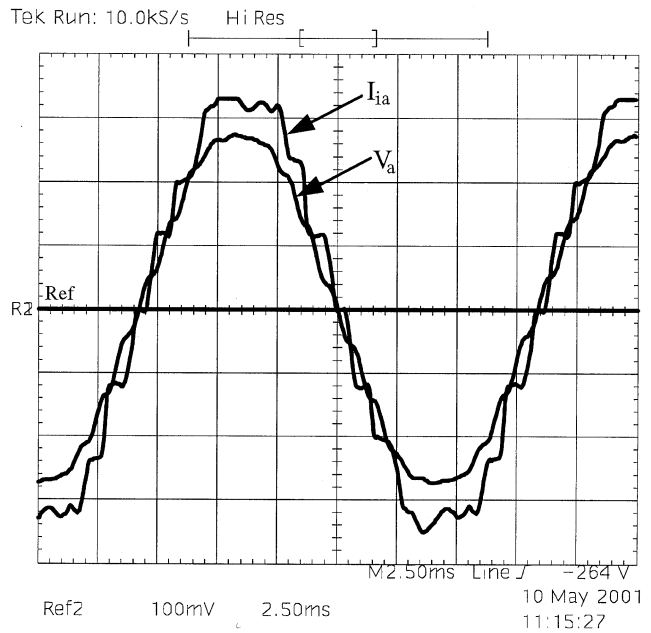

Fig. 14. Input current and input voltage in the same phase. Scales: 2 ms/div, 10 A/div, 100 V/div.

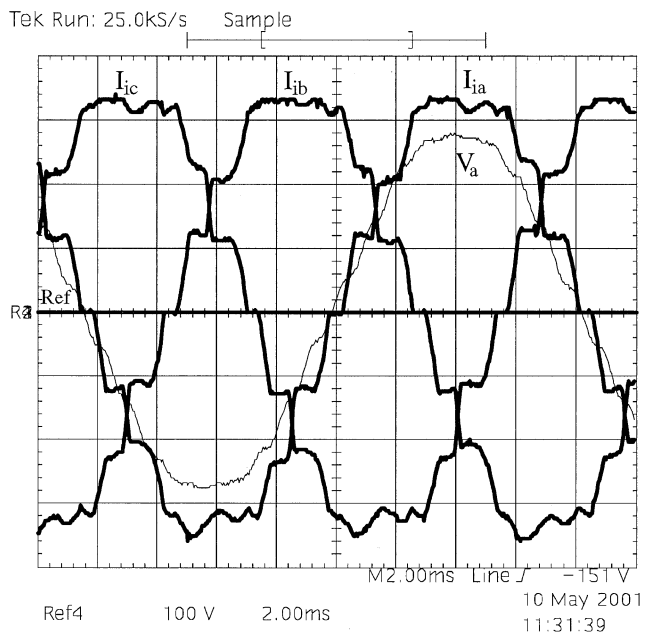

Fig. 15. Line currents. Scales: 2 ms/div, 10 A/div, 100 V/div.

a) Positive viewpoints

- No needs for current sensing, since the balance of the DC-link currents are get by the secondary windings series connected of the high-frequency transformers.
- The command circuitry is very simple. Only one IC with two pulse-transformers and one voltage regulator are used to control and drive all of the active switches.
- The step-down topology (buck-based mode) avoid a rush current to charge the small output capacitor in startup and this capacitor does not need to be electrolytic (lifetime).

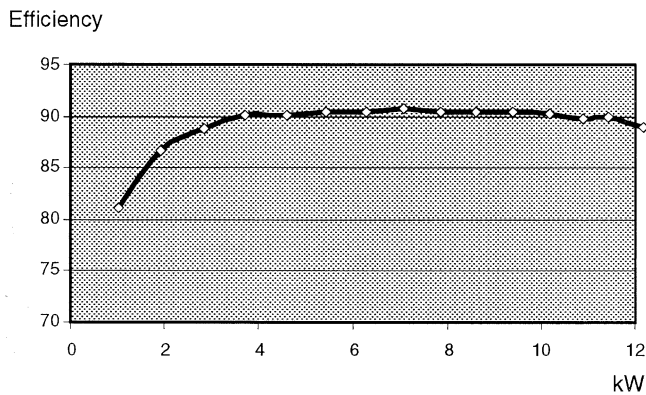

Fig. 16. Efficiency.

- The autotransformer rate is only 20% of the output power.
- The IPT's are eliminated.
- The ZVS is guaranteed for every active switches (the phase shift PWM technique is applied).
- Only two high current rectifier diode are used in the output.
- Efficiency is higher than 90%. It could be increased if the conduction losses were reduced (for instance: high current diodes replace schottky diodes).

b) Positive viewpoints

- There are two stages: an 18-pulse rectifier in line with the power flow and a dc-to-dc high frequency stage.
- Excess of the static devices: there are 12 diodes for the three full-wave three-phase rectifiers and 12 switches for the three full-bridge dc-dc converters.

REFERENCES

- [1] J. W. Kolar, "Status of the techniques of three-phase rectifier systems with low effects on the mains," in *Proc. INTELEC Conf.*, sec. 14.1., 1999.
- [2] J. W. Kolar, U. Drofenik, and F. C. Zach, "Vienna rectifier II—a novel single-stage high-frequency isolated three-phase PWM rectifier," in *Proc. APEC Conf.*, vol. 1, 1998, pp. 23–33.
- [3] Y. Nishida, T. Kondoh, M. Ishikawa, and K. Yasui, "Three-phase PWM-current-source type PFC rectifier (theory and practical evaluation of 12 kW real product)," in *Proc. PCC Conf.*, vol. 3, 2002, pp. 1217–1222.
- [4] D. Borgonovo, Y. R. Novaes, and I. Barbi, "A three-phase three-switch two-level PWM rectifier," in *Proc. IEEE PESC Conf.*, 2003, pp. 1075–1079.
- [5] D. A. Paice, *Power Electronic Converter Harmonic Multipulse Methods for Clean Power*. New York: IEEE Press, 1996.
- [6] S. Choi, P. N. Enjeti, and I. J. Pitel, "Polyphase transformer arrangements with reduced kVA capacities for harmonic current reduction in rectifier-type utility interface," *IEEE Trans. Power Electron.*, vol. 11, pp. 680–690, Sept. 1996.

- [7] F. J. M. Seixas and I. Barbi, "A new 12 kW three-phase 18-pulse high power factor AC-DC converter with regulated output voltage for rectifier units," in *Proc. INTELEC Conf.*, sec. 14.2, 1999.
- [8] —, "A new 18-pulse ac-dc converter with regulated dc output and high power factor for three-phase applications," in *Proc. Brazilian Power Electron. Conf.*, 1999, pp. 582–587.
- [9] G. R. Kamath, D. Benson, and R. Wood, "A novel autotransformer based 18-pulse rectifier circuit," in *Proc. IEEE APEC Conf.*, vol. 2, 2002, pp. 795–801.
- [10] —, "A wide input range active multi-pulse three-phase rectifier for utility interface of power electronic converters," in *Proc. IEEE IAS Conf.*, 2002, pp. 2514–2519.
- [11] C. Niermann, "New rectifier circuits with low mains pollution and additional low cost inverter for energy recovery," in *Proc. EPE Conf.*, 1989, pp. 1131–1136.
- [12] C. A. Muñoz and I. Barbi, "A new high-power-factor three-phase AC-DC converter: analysis, design, and experimentation," *IEEE Trans. Power Electron.*, vol. 14, pp. 90–96, Jan. 1999.
- [13] F. J. M. Seixas and I. Barbi, "A new three-phase low THD power supply with high-frequency isolation and 60 V/200 A regulated dc output," in *Proc. IEEE PESC Conf.*, Jun. 2001, pp. 1629–1634.
- [14] F. J. M. Seixas, "12 kW high power factor ac-dc converters using autotransformer with multipulse differential connection," Ph.D. dissertation, UFSC/INEP, Federal Univ. Santa Catarina, Santa Catarina, Brazil, 2003.
- [15] B. Andreyckak, "Phase shifted, zero voltage transition design consideration and the UC3875 PWM controller," *Applicat. Note U-136A*, Unirode Corporation, 1997.



Falcondes José Mendes de Seixas was born in Jales, SP, Brazil in 1965. He received the B.S. degree in electrical engineering from the Engineering School of Lins, Brazil, in 1988 and the M.S. and Ph.D. degrees in electrical engineering from the Federal University of Santa Catarina, Florianópolis, Brazil, in 1993 and 2001, respectively.

Currently, he is an Assistant Professor at the Department of Electrical Engineering, São Paulo State University, Ilha Solteira, Brazil. His research interests include power factor correction, switching mode

power supplies, and multipulse transformer applications.

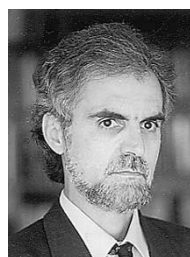

Ivo Barbi was born in Gaspar, Santa Catarina, Brazil in 1949. He received the B.S. and M.S. degrees in electrical engineering from the Federal University of Santa Catarina, Florianópolis, Brazil, in 1973 and 1976 respectively, and the Ph.D. degree from the Institut National Polytechnique de Toulouse, France, in 1979.

He founded the Brazilian Power Electronics Society and the Power Electronics Institute of the Federal University of Santa Catarina. He is currently a Professor with the Power Electronics Institute, Federal University of Santa Catarina.

power supplies, and multipulse transformer applications.